

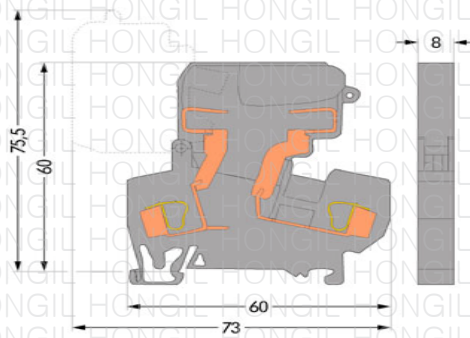

Item no.: 281-611  
 Product description: FUSED DISCONNECT TERMINAL BLOCK WITH PIVOTABLE FUSE HOLDER; for miniature metric fuses 5 x 20 mm; WITHOUT BLOWN FUSE INDICATION; CENTER MARKING; FRONT-ENTRY; CAGE CLAMP® CONNECTION



Packing unit 50 pieces  
 RoHS compliant

Product group	1 (Rail Mounted Terminal Blocks)
for miniature metric fuses	5 x 20 mm
Cross section from [mm <sup>2</sup> ]	0.08 mm <sup>2</sup>
Cross section to [mm <sup>2</sup> ]	4 mm <sup>2</sup>
Cross section from [AWG]	28 AWG
Cross section to [AWG]	12 AWG
Connection method	CAGE CLAMP® CONNECTION
Measured voltage EN	800 V
Measured shock voltage	8 kV
Pollution degree	3
Current intensity EN	10 A
Current intensity EN	6.3 A
Weight	17.26 g
Color	gray
Wiring type	Front-entry
No. of connection Points	2
No. of potentials	2
Height	60 mm
Height	2.36 in
Width	8 mm
Width	0.315 in
Depth	60 mm