

# POWER RELAY

# 1 POLE—16 A (HEAVY POWER CONTROL) VSB SERIES

RoHS compliant

## ■ FEATURES

- All or nothing relay
- UL, CSA, VDE, SEV, FIMKO, SEMKO, IMQ, ÖVE, BSI recognized
- Working class: C
- Type of service: continuous duty
- Heavy duty 16 A miniature power relay
- UL Class B (130°C) insulation
- High isolation in small package
  - Insulation distance: 8 mm
  - Dielectric strength: 5,000 VAC (between coil and contacts)
  - Surge strength: 10,000 V
- Low power consumption and high sensitivity type available VSB-S)
- Plastic sealed (with tape) type available
- RoHS compliant since date code:0523  
Please see page 6 for more information



## ■ ORDERING INFORMATION

[Example]      VSB - 12 S T B  
                   (a) (\*) (b) (c) (d) (e)

(a)	Series Name	VSB: VSB Series
(b)	Nominal Voltage	Refer to the COIL DATA CHART
(c)	Coil Type	Nil : Standard type S : High sensitivity type
(d)	Contact Arrangement	M : 1 form A (SPST-NO) T : 1 form C (SPDT)
(e)	Enclosure	B : Flux free type C : Plastic sealed type (with tape)

Note: Actual marking omits the hyphen (-) of (\*)

# VSB SERIES

## ■ SAFETY STANDARD AND FILE NUMBERS

UL508, 873 (File No. E56140, E108658)

C22.2 No. 14 (File No. LR35579)

VDE0435, 0631, 0700 (File No. 11039-4940-0005/30K)

Nominal voltage	Contact rating
3 to 100 VDC	1/3 HP 125 VAC/250 VAC 16 A 30 VDC/250 VAC resistive Pilot duty C 150

## ■ SPECIFICATIONS

Item		Standard Type	High Sensitive Type
		VSB-( )	VSB-( )-S
Contact	Arrangement	1 form A (SPST-NO) or 1 form C (SPDT)	
	Material	Silver alloy (AgSnO)	
	Style	Single	
	Resistance (initial)	Maximum 200 mΩ (at 1 A 6 VDC)	
	Rating (resistive)	16 A 250 VAC/30 VDC	
	Maximum Carrying Current	16 A	
	Maximum Switching Power	4,000 VA, 480 W	
	Maximum Switching Voltage	380 VAC, 150 VDC	
	Maximum Switching Current	16 A	
	Minimum Switching Load*1	100 mA 5 VDC	
Coil	Nominal Power (at 20°C)	0.7 to 0.75 W	0.53 W
	Nominal Voltage (at 20°C)	0.35 to 0.37 W	0.26 W
	Operating Temperature	-40°C to +65°C (no frost)	-40°C to +75°C (no frost)
Time Value	Operate (at nominal voltage)	Maximum 15 ms	
	Release (at nominal voltage)	Maximum 10 ms	
Insulation	Resistance (at 500 VDC)	Minimum 1,000 MΩ	
	Dielectric Strength	between open contacts	1,000 VAC 1 minute
		between coil and contacts*2	5,000 VAC 1 minute
Surge Strength*3	10,000 V (at 1.2 x 50μs)		
Life	Mechanical	2 × 10 <sup>7</sup> operations minimum	
	Electrical	1 × 10 <sup>5</sup> operations minimum (contact rating)	
Other	Vibration	Misoperation	10 to 55 Hz (double amplitude of 1.5 mm)
		Endurance	10 to 55 Hz (double amplitude of 1.5 mm)
	Resistance	Misoperation	100 m/s <sup>2</sup> (11 ±1 ms)
		Endurance	1,000 m/s <sup>2</sup> (6 ±1 ms)
Weight	Approximately 18 g		

\*1 Minimum switching loads mentioned above are reference values. Please perform the confirmation test with the actual load before production since reference values may vary according to switching frequencies, environmental conditions and expected reliability levels.

\*2 IMQ 

\*3 IMQ 

# VSB SERIES

## ■ COIL DATA CHART

	MODEL	Nominal voltage	Coil resistance (±10%)	Must operate voltage	Must release voltage	Nominal power
Standard Type	VSB- 3 ( ) ( )	3 VDC	12.5 Ω	2.1 VDC	0.3 VDC	0.72 W
	VSB- 5 ( ) ( )	5 VDC	36 Ω	3.5 VDC	0.5 VDC	0.70 W
	VSB- 6 ( ) ( )	6 VDC	50 Ω	4.2 VDC	0.6 VDC	0.72 W
	VSB- 9 ( ) ( )	9 VDC	115 Ω	6.3 VDC	0.9 VDC	0.70 W
	VSB- 12 ( ) ( )	12 VDC	200 Ω	8.4 VDC	1.2 VDC	0.72 W
	VSB- 14 ( ) ( )	14 VDC	280 Ω	9.8 VDC	1.4 VDC	0.70 W
	VSB- 18 ( ) ( )	18 VDC	460 Ω	12.6 VDC	1.8 VDC	0.70 W
	VSB- 24 ( ) ( )	24 VDC	820 Ω	16.8 VDC	2.4 VDC	0.70 W
	VSB- 36 ( ) ( )	36 VDC	1,850 Ω	25.2 VDC	3.6 VDC	0.70 W
	VSB- 48 ( ) ( )	48 VDC	3,300 Ω	33.6 VDC	4.8 VDC	0.70 W
	VSB- 60 ( ) ( )	60 VDC	5,100 Ω	42.0 VDC	6.0 VDC	0.70 W
	VSB-100 ( ) ( )	100 VDC	13,400 Ω	70.0 VDC	10.0 VDC	0.75 W
High Sensitivity Type	VSB- 3S ( ) ( )	3 VDC	17 Ω	2.1 VDC	0.3 VDC	0.53 W
	VSB- 5S ( ) ( )	5 VDC	47 Ω	3.5 VDC	0.5 VDC	0.53 W
	VSB- 6S ( ) ( )	6 VDC	68 Ω	4.2 VDC	0.6 VDC	0.53 W
	VSB- 9S ( ) ( )	9 VDC	155 Ω	6.3 VDC	0.9 VDC	0.53 W
	VSB- 12S ( ) ( )	12 VDC	270 Ω	8.4 VDC	1.2 VDC	0.53 W
	VSB- 14S ( ) ( )	14 VDC	370 Ω	9.8 VDC	1.4 VDC	0.53 W
	VSB- 18S ( ) ( )	18 VDC	610 Ω	12.6 VDC	1.8 VDC	0.53 W
	VSB- 24S ( ) ( )	24 VDC	1,100 Ω	16.8 VDC	2.4 VDC	0.53 W
	VSB- 36S ( ) ( )	36 VDC	2,450 Ω	25.2 VDC	3.6 VDC	0.53 W
	VSB- 48S ( ) ( )	48 VDC	4,400 Ω	33.6 VDC	4.8 VDC	0.53 W
	VSB- 60S ( ) ( )	60 VDC	6,800 Ω	42.0 VDC	6.0 VDC	0.53 W
	VSB-100S ( ) ( )	100 VDC	18,560 Ω	70.0 VDC	10.0 VDC	0.53 W

Note: All values in the table are measured at 20°C

## CHARACTERISTIC DATA

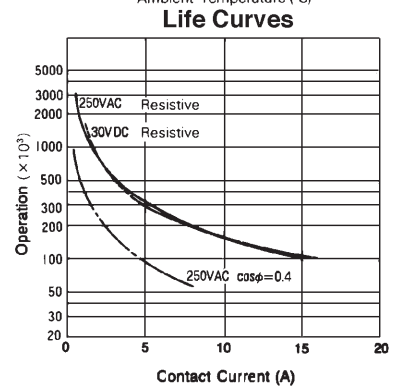
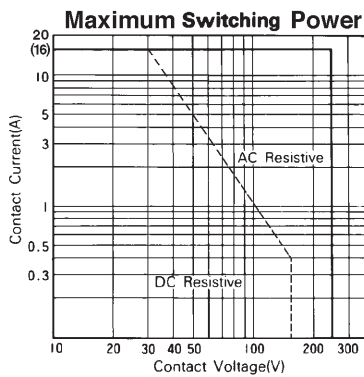
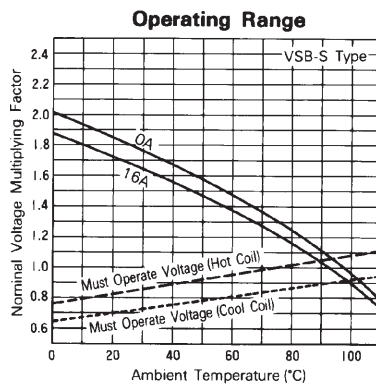
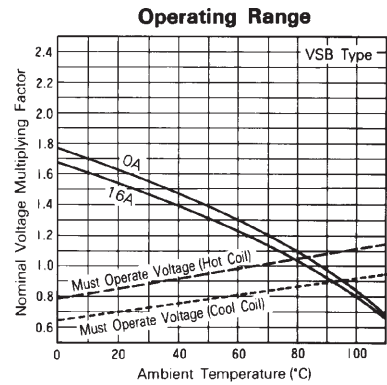
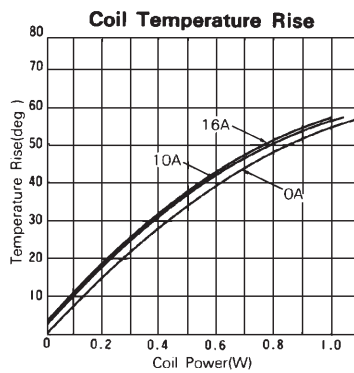
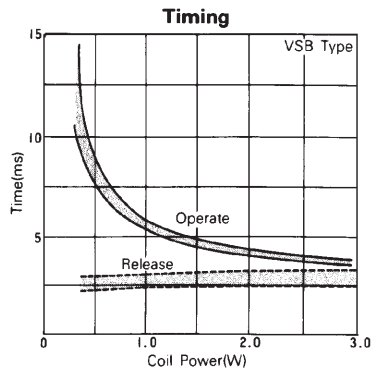

## REFERENCE DATA

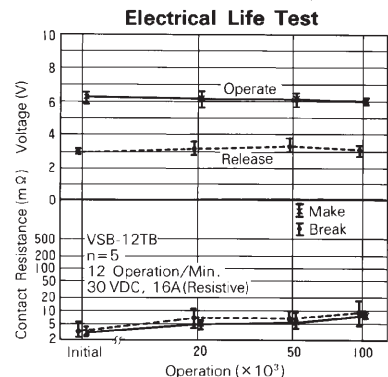
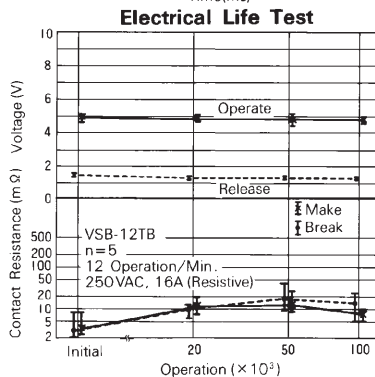
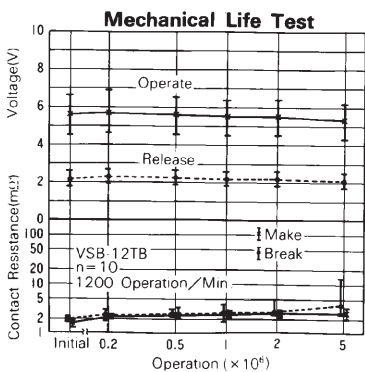
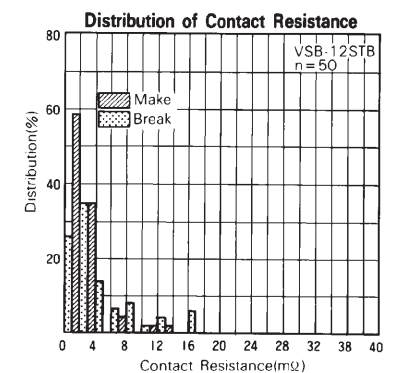
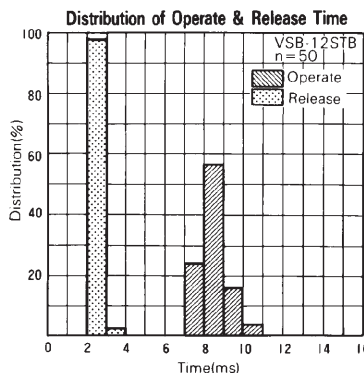
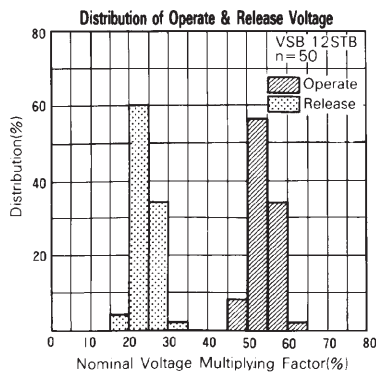

# VSB SERIES

## ■ DIMENSIONS

### ● Dimensions

#### VSB-M type

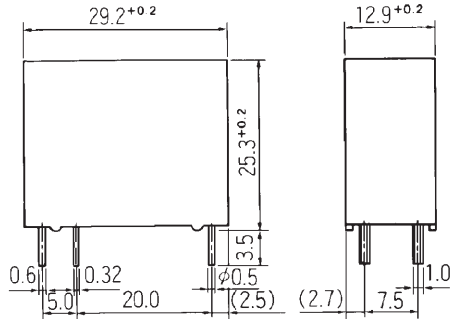

### ● Schematics (BOTTOM VIEW)

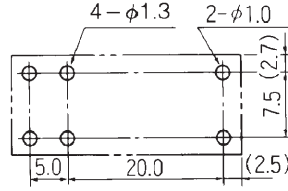

### ● PC board mounting hole layout (BOTTOM VIEW)

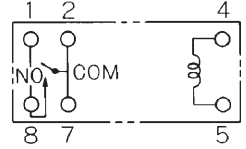

#### VSB type

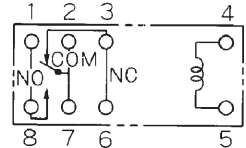
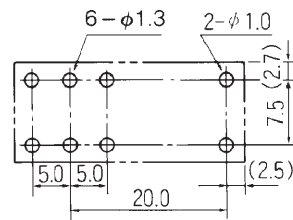
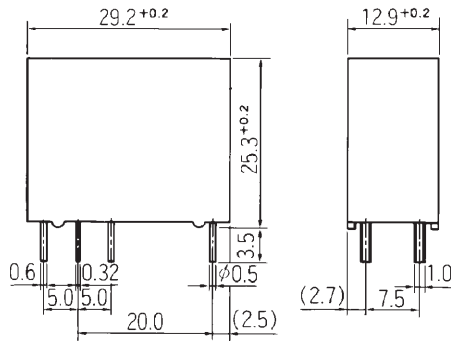

#### VSB-MC type (Plastic sealed type with tape)

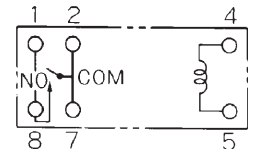
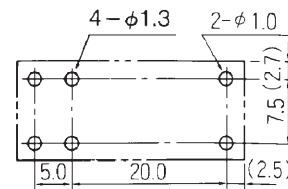
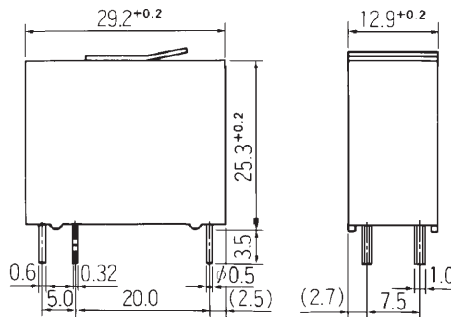

#### VSB-C type (Plastic sealed type with tape)

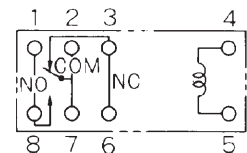
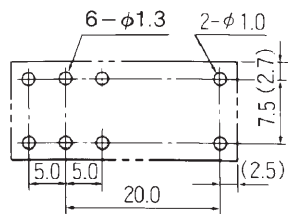
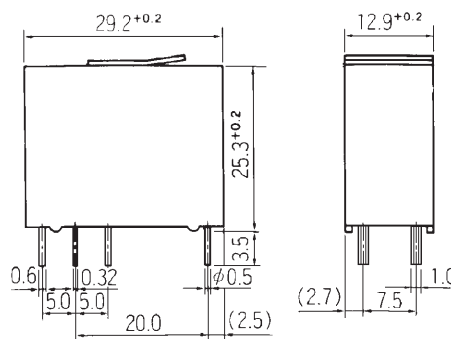

Unit: mm

## RoHS Compliance and Lead Free Relay Information

### 1. General Information

- Relays produced after the specific date code that is indicated on each data sheet are lead-free now. Most of our signal and power relays are lead-free. Please refer to Lead-Free Status Info. (<http://www.fujitsu.com/us/downloads/MICRO/fcai/relays/lead-free-letter.pdf>)
- Lead free solder paste currently used in relays is Sn-3.0Ag-0.5Cu.
- All signal and most power relays also comply with RoHS. Please refer to individual data sheets. Relays that are RoHS compliant do not contain the 5 hazardous materials that are restricted by RoHS directive (lead, mercury, chromium IV, PBB, PBDE).
- It has been verified that using lead-free relays in leaded assembly process will not cause any problems (compatible).
- "LF" is marked on each outer and inner carton. (No marking on individual relays).
- To avoid leaded relays (for lead-free sample, etc.) please consult with area sales office.
- We will ship leaded relays as long as the leaded relay inventory exists.

Note: Cadmium was exempted from RoHS on October 21, 2005. (Amendment to Directive 2002/95/EC)

### 2. Recommended Lead Free Solder Profile

- Recommended solder paste Sn-3.0Ag-0.5Cu.

#### Reflow Solder condition

**Flow Solder condition:**

Pre-heating: maximum 120°C  
Soldering: dip within 5 sec. at  
260°C solder bath

**Solder by Soldering Iron:**

Soldering Iron  
Temperature: maximum 360°C  
Duration: maximum 3 sec.

**We highly recommend that you confirm your actual solder conditions**

### 3. Moisture Sensitivity

- Moisture Sensitivity Level standard is not applicable to electromechanical relays.

### 4. Tin Whisker

- Dipped SnAgCu solder is known as low risk tin whisker. No considerable length whisker was found by our in house test.

## Fujitsu Components International Headquarter Offices

**Japan**

Fujitsu Component Limited  
Gotanda-Chuo Building  
3-5, Higashigotanda 2-chome, Shinagawa-ku  
Tokyo 141, Japan  
Tel: (81-3) 5449-7010  
Fax: (81-3) 5449-2626  
Email: [promothq@ft.ed.fujitsu.com](mailto:promothq@ft.ed.fujitsu.com)  
Web: [www.fcl.fujitsu.com](http://www.fcl.fujitsu.com)

**North and South America**

Fujitsu Components America, Inc.  
250 E. Caribbean Drive  
Sunnyvale, CA 94089 U.S.A.  
Tel: (1-408) 745-4900  
Fax: (1-408) 745-4970  
Email: [marcom@fcai.fujitsu.com](mailto:marcom@fcai.fujitsu.com)  
Web: <http://www.fujitsu.com/us/services/edevices/components/>

**Europe**

Fujitsu Components Europe B.V.  
Diamantlaan 25  
2132 WV Hoofddorp  
Netherlands  
Tel: (31-23) 5560910  
Fax: (31-23) 5560950  
Email: [info@fceu.fujitsu.com](mailto:info@fceu.fujitsu.com)  
Web: <http://www.fujitsu.com/emea/services/components/>

**Asia Pacific**

Fujitsu Components Asia Ltd.  
102E Pasir Panjang Road  
#04-01 Citilink Warehouse Complex  
Singapore 118529  
Tel: (65) 6375-8560  
Fax: (65) 6273-3021  
Email: [fcal@fcal.fujitsu.com](mailto:fcal@fcal.fujitsu.com)  
Web: <http://www.fujitsu.com/sg/services/micro/components/>

©2005 Fujitsu Components America, Inc. All rights reserved. All trademarks or registered trademarks are the property of their respective owners.

Fujitsu Components America does not warrant that the content of datasheet is error free. In a continuing effort to improve our products Fujitsu Components America, Inc. reserves the right to change specifications/datasheets without prior notice. Rev. 12/12/2005.